

Hellwig PRODUCTS.com

559-734-7451 800-367-5480 FAX 559-734-7460

INSTALLATION INSTRUCTIONS

Thank you for purchasing a quality Hellwig Product.

PLEASE READ THIS INSTRUCTION SHEET COMPLETELY BEFORE STARTING YOUR INSTALLATION

TORQUE TABLE

BOLT THREAD DIAMETER : 3/8" = 20-30 ft. lbs. - 7/16" = 35-45 ft. lbs. - 1/2" = 50-70 ft. lbs. - 9/16" = 70-90 ft. lbs.

NOTE : THESE AIR SPRINGS ARE DESIGNED TO MOUNT TO THE AXLE AND THE FRAME , SOME DRILLING ON THE VEHICLES FRAME MAY BE NECESSARY.

NOTE : IT MAY BE NECESSARY TO JACK THE VEHICLE BY THE FRAME TO MAKE ENOUGH SPACE BETWEEN THE AXLE AND THE FRAME TO INSTALL THE AIR SPRING. REMOVAL OF THE REAR TIRES MAY BE NECESSARY TO GAIN ACCESS TO THE AREA ON THE FRAME WHERE THE HOLES ARE TO BE DRILLED. NOT ALL VEHICLES WILL REQUIRE REMOVAL OF THE REAR TIRES. RAISE THE VEHICLE BY THE FRAME TO CHECK FOR ACCESS CLEARANCE.

NOTE : IF THE REAR TIRES ARE TO BE REMOVED SUPPORT THE VEHICLES FRAME BY USING JACK STANDS AND BLOCKING THE FRONT VEHICLES TIRES.

1. As per the diagrams , attach the air spring to the frame bracket with the locknuts provided. On the air spring that mounts on the passenger side of the vehicle , install the heat shield between the air spring and the vehicles frame.
Tighten just slightly to allow for adjustment later.
2. Use the 3/8" bolt and lock washer provided attach to the lower axle bracket at the bottom of the air spring. There are a variety of drilled holes on this bracket. It may be necessary to change holes after mounting for best fit so that the air spring is properly aligned on your particular vehicle. **Leave loose at this time to allow for adjustment later.**
3. Install the brass air fitting into the top of the air spring. Tighten the fitting completely so that some of the thread sealant gets down inside the threads of the air spring. Align the air fitting so that the air hose points in the direction desired for your particular vehicle.
4. Locate the rubber bump stop bracket that is mounted to the bottom of the vehicles frame and directly above the vehicles axle. Remove the bump stop brackets , these items will **not** be reused.
5. Place the air spring assembly on top of the vehicles axle. Place the frame bracket on the outside of the vehicles frame. The frame bracket needs to be up against the bottom and flat to the outside of the vehicles frame. The frame bracket should nest into the radius and be up against the bottom of the vehicles frame. The lower holes on the side of the frame bracket are for clearance over the rivets that are on the vehicles frame. If your vehicle does not have rivets on the frame these holes will not be used.
6. With the assembled air spring in position, align the brackets so that the air spring is as straight as possible. The frame bracket should be centered on the reinforced area for the bump stop bracket. With the brackets in the proper position use the upper holes in the upper frame brackets to mark the locations on the vehicles frame, where the mounting holes will be drilled for mounting. Before drilling the vehicles frame make sure and move any wires , hoses or any other items from inside the frame to avoid any damage when drilling the mounting holes. **Do the same on opposite frame.**
7. Using a 7/16" drill bit , drill the two holes on the vehicles frame. Place the air spring into position , insert the bolts with washers provided through the frame brackets and the vehicles frame. The threaded end of the bolts will be on the inside of the vehicles C-channel frame. The inner frame bracket will mount flush against the inside of the frame and to the top of the air spring. There are two inner frame brackets per air spring they are bent opposite each other. One on the front and one on the rear , when properly installed the bent legs of the brackets will be facing each other. The small corners that are trimmed off on the inner frame brackets will mount towards the brass air line fitting. Remove the air spring upper lock nut , insert through the frame bracket re-install the lock nut do not over tighten. **Leave loose to allow for adjustment later.** The inner frame brackets are designed to allow for a tunnel next to the vehicles frame so any electrical wires , fuel lines or hoses can be placed back against the frame as before. Use the plastic insulator covers that are supplied for protection as needed.

NOTE : use bracket # 20800247 if extra clearance is required for relocating wires, fuel and brake lines in the frame rails (SEE LAST PAGE FOR ILLUSTRATION).

Hellwig PRODUCTS.com

559-734-7451 800-367-5480 FAX 559-734-7460

8. Place the carriage bolts into the lower axle brackets so that the threads hang down next to the axles. Mount the axle clamp brackets under the vehicles axle to align with the carriage bolts. Be sure to move any brake lines or fuel hoses or other items on the axle to avoid damage during installation. Attach the axle brackets with the carriage bolts with the locknuts provided. Either set of holes in the lower axle bracket can be used. Choose for best fit as per your vehicle. **Leave loose at this time to allow for adjustment later.**
9. Move the frame bracket on the frame and the axle bracket on the axle to align the air springs as straight up and down as possible. Once the air springs are properly aligned make sure all lines , hoses and wires are out of the way so that they will not be crushed during installation. Rotate the heat shield to protect the air spring from the vehicles exhaust. Torque all frame mounting hardware to specified rate. Double check the alignment after tightening. Torque the top air spring lock nuts to **max. 25 ft lbs.**
10. Tighten the axle clamp locknuts completely , be careful as to not bend the brackets. The corners of the lower axle brackets will grip the top of the axle. This will prevent the bracket from rotating on the axle. With the clamp bracket properly installed at the bottom of the axle it will not rotate.
11. Cut the **1/4"** air line into two (2) equal lengths. Make sure that the air line has a straight clean cut to avoid air leaks after installation. Connect one end of the air line to the brass air fitting on top of the air spring. See the air hose fitting diagram for the style of fittings that are supplied in your particular kit. If an air compressor is being installed on your vehicle follow the mounting instructions for proper hose routing.
12. Route the air line to the desired fill location. Using the supplied plastic tie straps , tie the air line to either existing wires , lines or hoses. Be careful , and keep the air lines away from the exhaust system to avoid damage. Use the black hose insulator if needed for extra protection. Keep air line and mounting hardware minimum **1-1/2"** from making contacting with any of the exhaust components. Find a location , either on the vehicles frame or bumper to install the air fill valve. Using a **5/16"** drill bit , drill a hole at desired fill location. Your kit is supplied with (2) schrader air fill valves , one per air spring. **NOTE :** see page #5 for the style of air fill valve that is supplied in your installation kit.
13. With the air springs properly mounted and secured to the vehicle , inflate the air springs to approximately **30 lbs PSI.** Using a squirt bottle with a mixture of **30%** liquid dish soap and **70%** water check the entire system for air leaks. If an air leak is detected remove the air pressure from the entire system before repairing the leak. Usually tightening the fittings will repair the leak. Re-inflate and retest the system until no leaks are detected.
14. Keep a minimum of **5-10 lbs PSI** in your systems at all times to avoid any damage. For best ride use only enough air pressure as required to level the vehicle. If a firmer ride is desired , more pressure can be used. The air springs can be inflated to any level between **10-100 PSI.**
15. Check air pressure in the system regularly to ensure system performance and to maintain the warranty. Just like tires the air pressure in the system will vary due to temperature changes. For your air springs to function properly they must be checked on a regular basis.

NOTE : NEVER LOAD THE VEHICLE THAT THIS KIT IS BEING INSTALLED ON BEYOND THE MANUFACTURERS MAXIMUM GROSS VEHICLE WEIGHT RATING

ATTENTION INSTALLER: BE SURE THAT THE CUSTOMER RECEIVES THIS INSTRUCTION SHEET, ALL IMORTANT NOTE CARDS AND THE WARRANTY FORM

IMPORTANT NOTE

DO NOT ATTEMPT ANY MODIFICATIONS TO THE VEHICLE OTHER THAN THOSE OUTLINED IN THIS INSTRUCTION SHEET. IF ANY INTERFERENCE OCCURS WITH GAS TANKS , BRAKE & FUEL LINES , EXHAUST PIPES , ETC., STOP YOUR INSTALLATION AND CONTACT HELLWIG PRODUCTS CO. FOR TECHNICAL ASSISTENCE OR INSTRUCTIONS.

NEVER LOAD THE VEHICLE THIS UNIT IS BEING INSTALLED ON BEYOND THE MANUFACTURERS MAXIMUM GROSS VEHICLE WEIGHT RATING.

WHEN LIFTING THE VEHICLE WITH A JACK, BE SURE TO SET THE PARKING BRAKE AND BLOCK THE TIRES. USE SAFETY STANDS AND SUPPORT THE VEHICLE BY THE AXLE TO KEEP THE SUSPENSION LOADED.

WHEN REINSTALLING THE TIRES ON THE VEHICLE , CHECK THE MANUFACTURERS SPECIFICATIONS FOR PROPER TORQUE RATINGS.

MOVE ANY ELECTRICAL WIRES , FUEL & BRAKE LINES , OR ANY OTHER OBJECTS INSIDE THE FRAME RAILS BEFORE DRILLING ANY HOLES TO AVOID DAMAGE TO ANY OF THE VEHICLES COMPONENTS.

BE SURE THE FLAT PLATES INSIDE THE FRAME RAILS ARE BEHIND ANY WIRES , LINES , OR HOSES TO AVOID PINCHING OR CRUSHING WHEN THE MOUNTING HARDWARE IS TORQUED TO THE SPECIFIED RATE.

THIS UNIT MUST BE MOUNTED SECURELY TO THE VEHICLE AT THE TOP AND BOTTOM MOUNTING BRACKETS PRIOR TO ADDING ANY AIR PRESSURE OR DAMAGE CAN OCCUR.

THE PROPER AIR SPRING SETUP HEIGHT IS BETWEEN FIVE (5) AND SIX AND ONE HALF (6-1/2) INCHES. BETWEEN THE TOP OF AIR SPRING END CAP TO BOTTOM OF AIR SPRING END CAP.

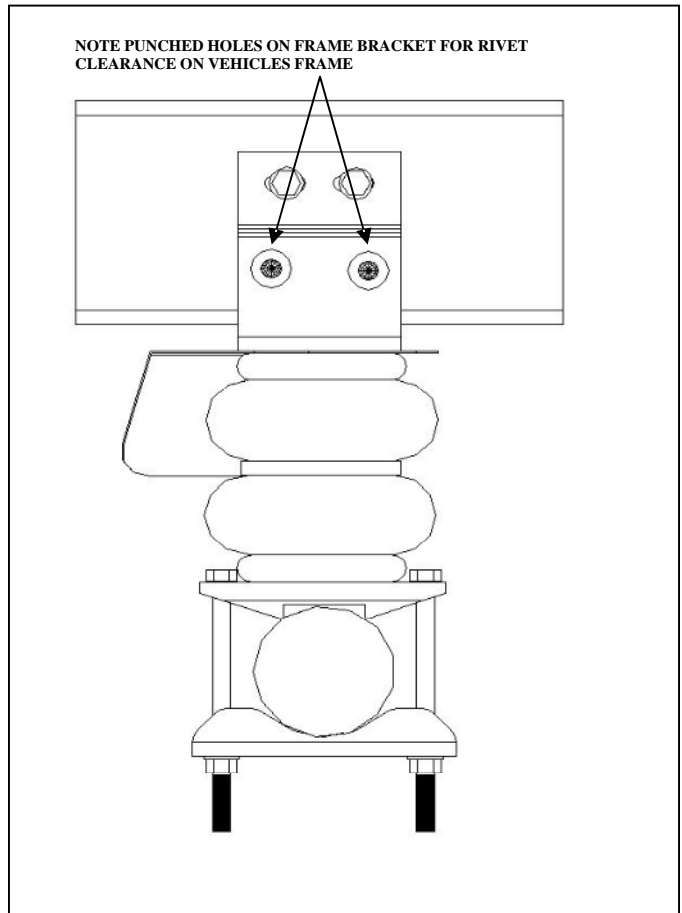
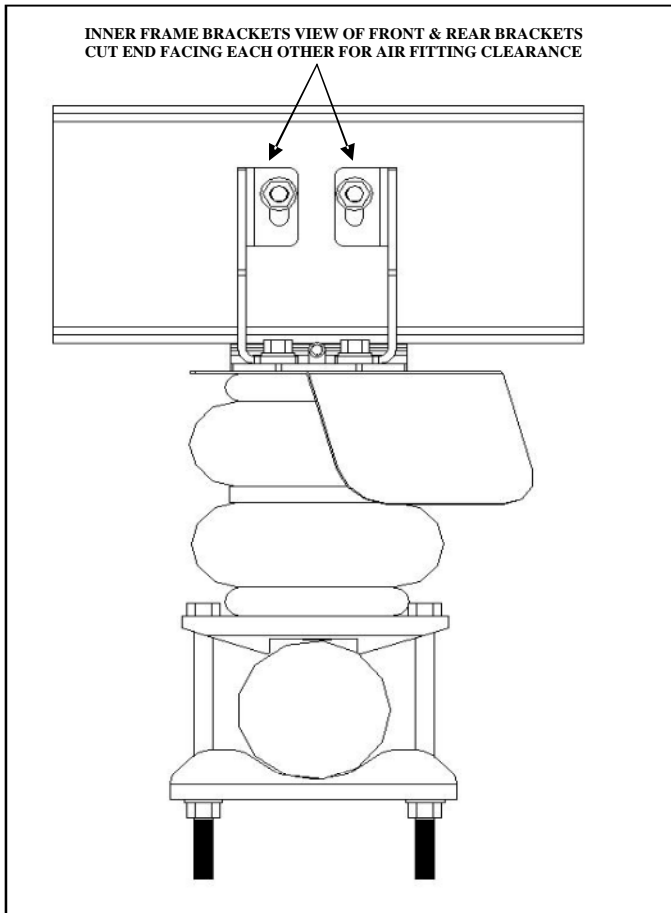
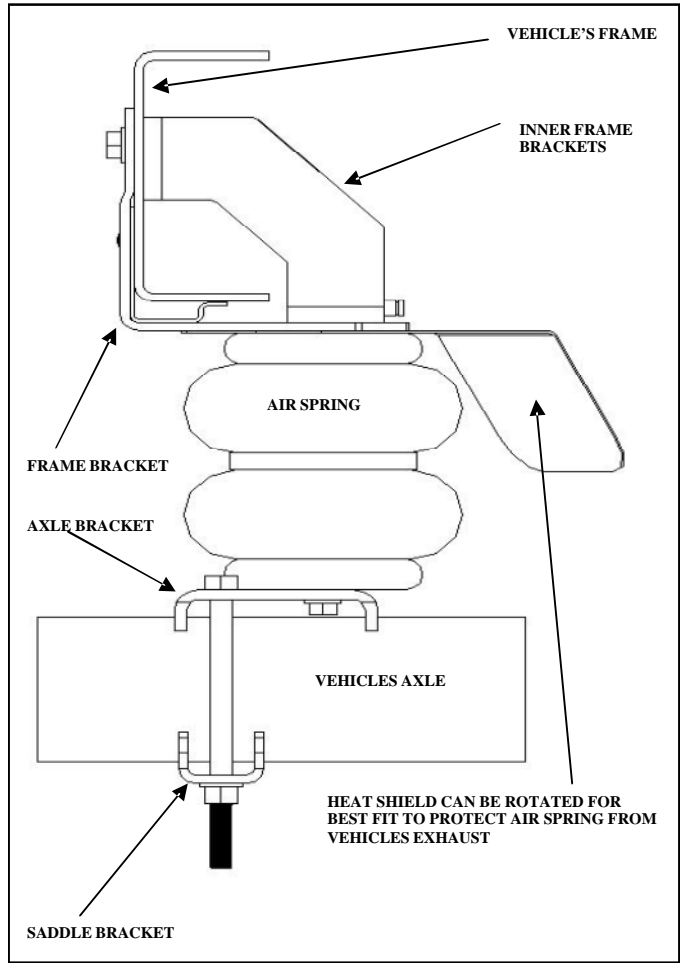
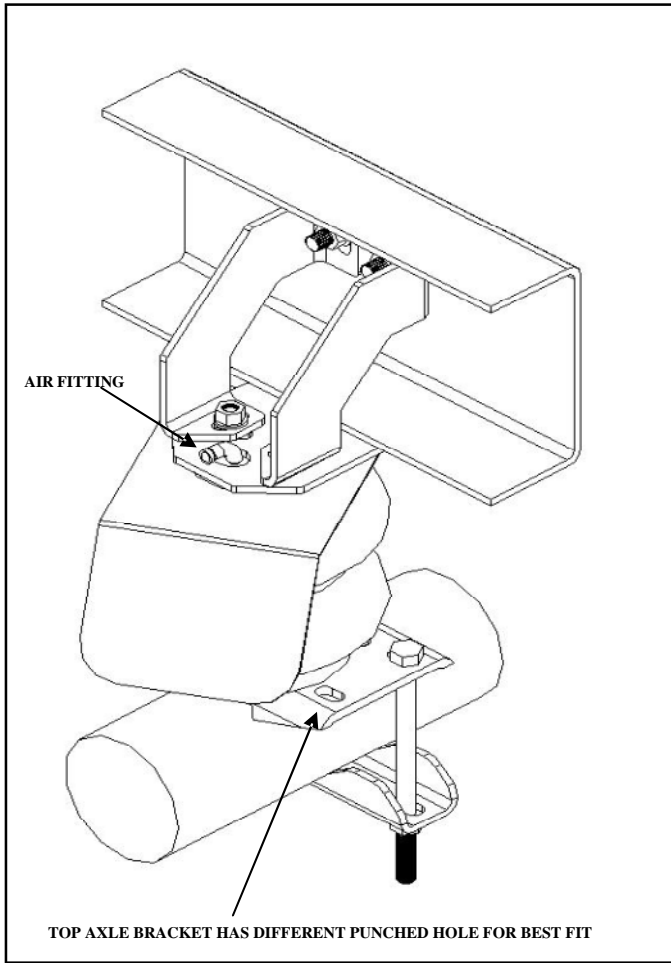

559-734-7451 800-367-5480 FAX 559-734-7460

BELLOWS QUICK DISCONNECT STYLE AIR FITTING

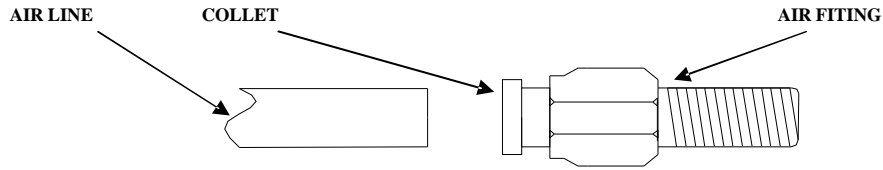

TO INSTALL AIR LINE, PRESS AIR LINE INTO THE COLLET ON THE AIR LINE FITTING UNTIL THE AIR LINE BOTTOMS IN THE FITTING THIS WILL LOCK THE AIR LINE INTO PLACE. TO REMOVE, PUSH THE COLLET IN, HOLD AND PULL ON THE AIR LINE THIS WILL RELEASE THE AIR LINE
 NOTE: MAKE SURE AIR LINE IS CUT STRAIGHT AND IS AS ROUND AS POSSIBLE TO MAKE A GOOD SEAL OR LEAKING MAY OCCUR

SCHRADER AIR FILL VALVE

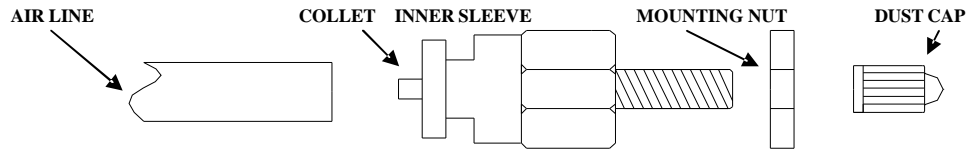

TO INSTALL AIR LINE ONTO THE SCHRADER VALVE FOLLOW INSTRUCTIONS AS STATED ABOVE BE CAREFUL NOT TO DAMAGE THE AIR LINE INNER SLEEVE.
 NOTE: SOME AIR LINE FITTINGS MAY OR MAY NOT HAVE THE INNER SLEEVE
 NOTE: MAKE SURE AIR LINE IS CUT STRAIGHT AND IS AS ROUND AS POSSIBLE TO MAKE A GOOD SEAL OR LEAKING MAY OCCUR.

SCHRADER VALVE W/BARB END FITTING



HOSE NUT STYLE FITTING

HOSE PORT CONNECTION
W/O TUBE INSERT CONNECTED

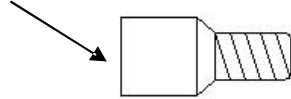

AIR LINE FARREL



AIR LINE HOSE END NUT

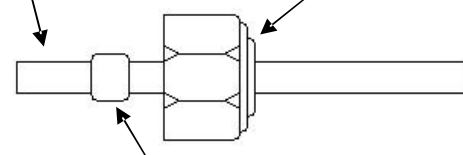

HOSE TUBE INSERT
(USE IF NOT ATTACHED TO HOSE PORT)

FERRAL

HOSE PORT CONNECTION
(W/TUBE INSERT CONNECTED)

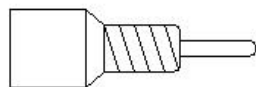

AIR LINE

HOSE END NUT

PLASTIC FERRAL

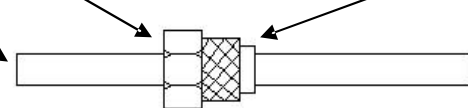

INSERT TUBE INTO AIR HOSE END IF NEEDED. BE SURE AIR HOSE IS CUT STRAIGHT AND CLEAN. RESHAPE AIR HOSE TO BE AS ROUND AS POSSIBLE. PLACE HOSE END NUT OVER HOSE, PUSH HOSE INTO HOSE PORT COMPLETELY. TIGHTEN TO BE SNUG, DO NOT OVER TIGHTEN OR DAMAGE TO THE CONNECTION MAY OCCUR.

**IT MAY BE NECESSARY TO RELOCATE THE FACTORY BRAKE LINE
ON THE FRAME TO ALLOW FOR EXTRA CLEARANCE FOR THE
MOUNTING OF THE AIR SPRING BRACKETS**

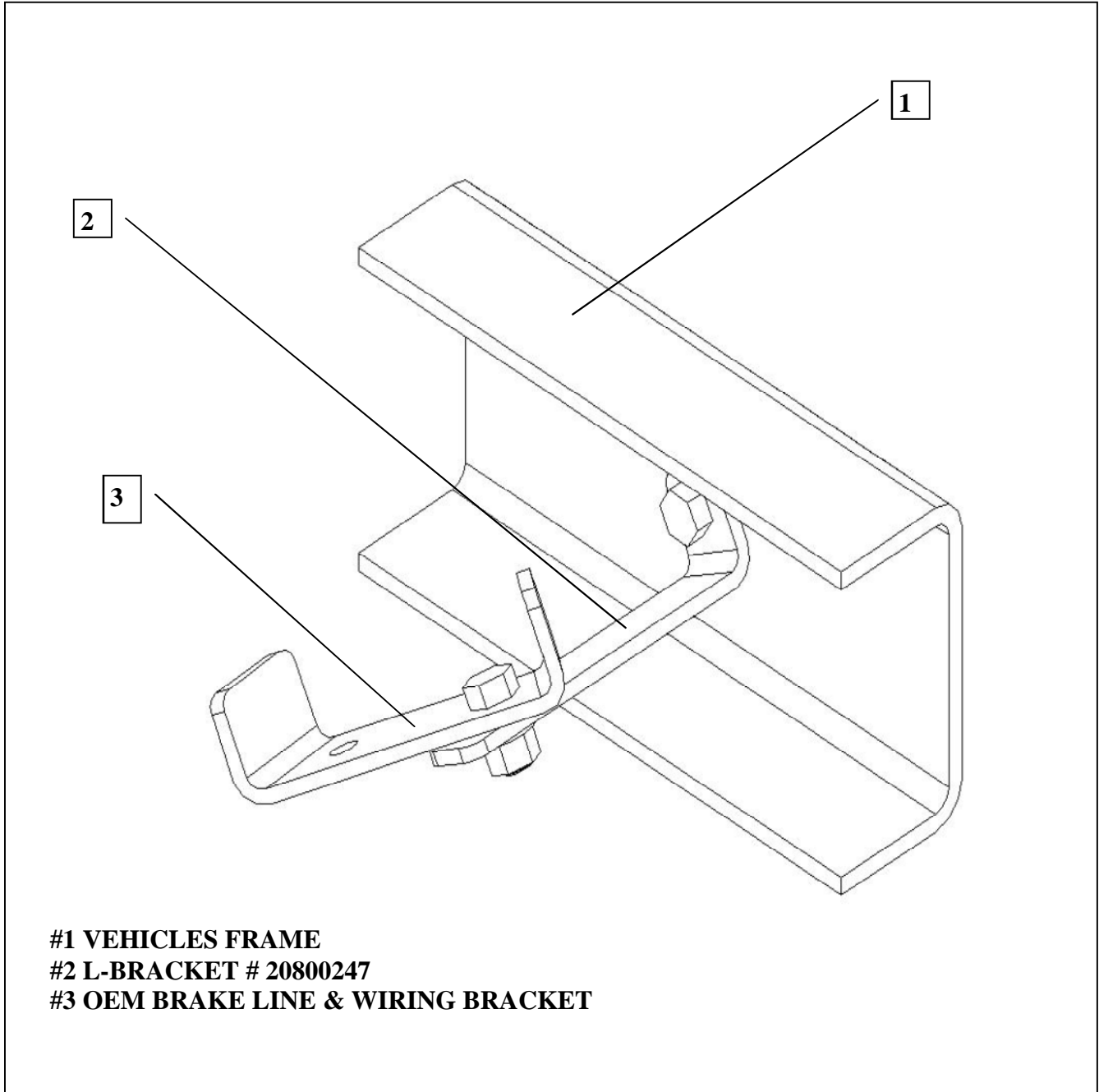



559-734-7451 800-367-5480 FAX 559-734-7460

**PARTS LIST
KIT # 6102**

PART #	QTY	DESCRIPTION
60102500	2	AIR SPRING
20800250	2	SADDLE BRACKET
208001851	2	FRAME BRACKET
20800247	1	BRAKE MOUNTING TAB
20801853	1	HEAT SHEILD
20801852	2	LH FRAME GUSSET
20801854	2	RH FRAME GUSSET
20800254	2	AXLE BRACKET
125000999	1	AIR LINE PARTS BAG # 999
121050214	18	1/4" AIR LINE
121091879	2	SHRAEDER AIR VALVE
121901001	2	1/4" X 8" AIR LOOM
121050221	8	7" TIE STRAP
125026102	1	SMALL PARTS BAG # 6102
135006102	1	INSTRUCTION SHEET (R-6102)